

Econo-Mate Tank Level Gauging System

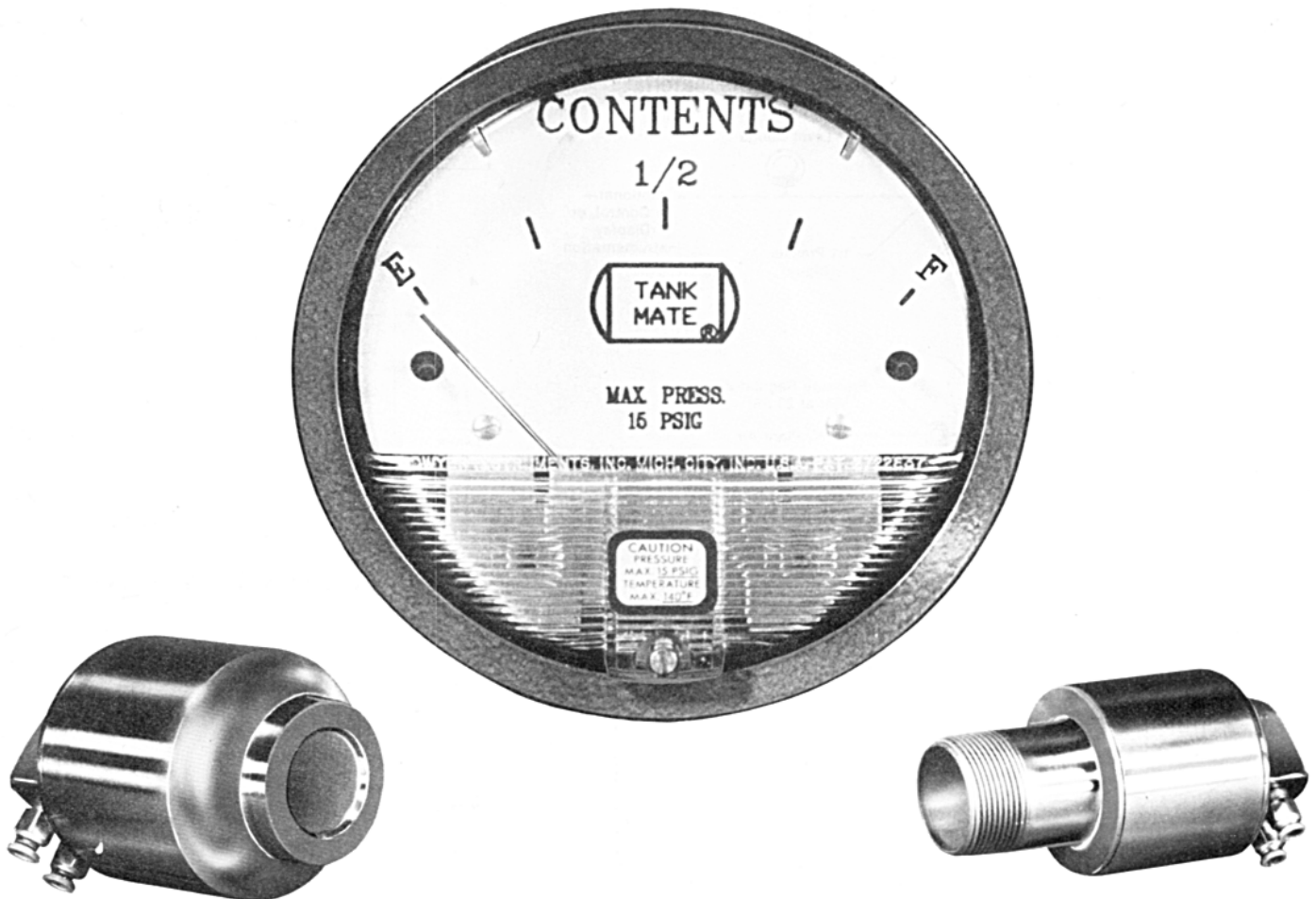

Complete Pneumatic Sensor Package

Sensor • Indicator

This system has everything you need to keep track of the amount of material in small process tanks at any given moment. Systems are offered with your choice of sanitary or industrial sensor. Sanitary sensors available include the 200WFC welding type for single shell tanks, the 205WF and 208WF for insulated tanks, and the 200CFC-2" clamp-type sensor. The model 417 industrial sensor with 1½" NPT thread also is offered in one of these packages.

All sensors are 316 stainless steel with stainless steel diaphragm. Sanitary sensors bear the 3A symbol.

The small dial size of the Tank Mate 4" flush mounted indicator is suited to the purpose of this package . . . to maintain a check on how full the tank is without the need to read the exact amount on hand. Level indicators will be calibrated in your choice of:

1. Percent full (graduated in 25% increments)
2. Pounds

This package affords the opportunity to put together a system with top quality Tank Mate components at savings of up to 57%.

TANK MATE ECONO-MATE GAUGING SETUP

Clean, pressurized air from the plant air system is sent through the Tank Mate air pressure regulator set at 20 PSI to the tank sensor. The sensor balances air pressure in a 1:1 ratio against the pressure of the product in the tank. The resultant air pressure is transmitted to the gauge where product level is displayed as a function of the weight of the material in the tank.

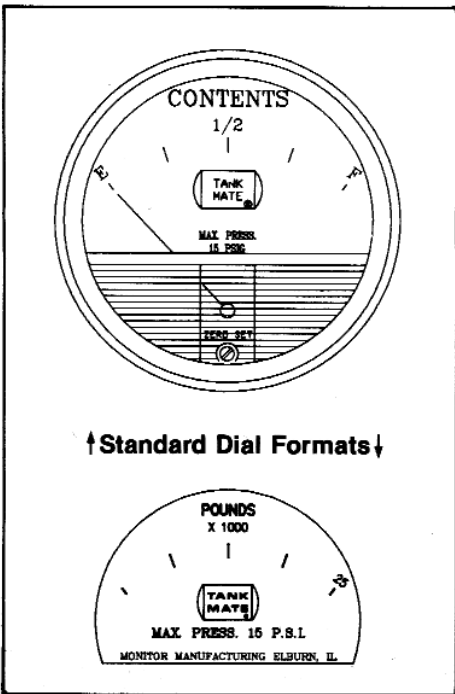
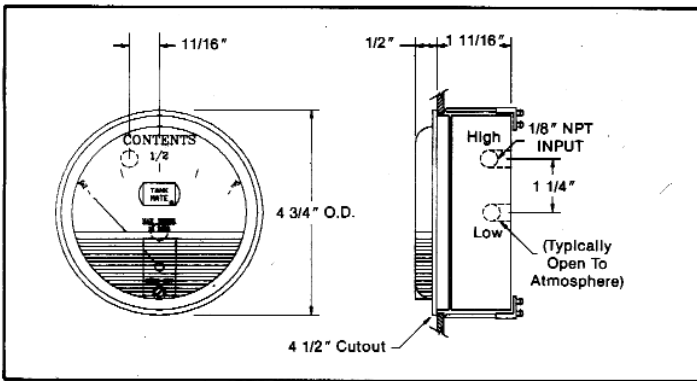
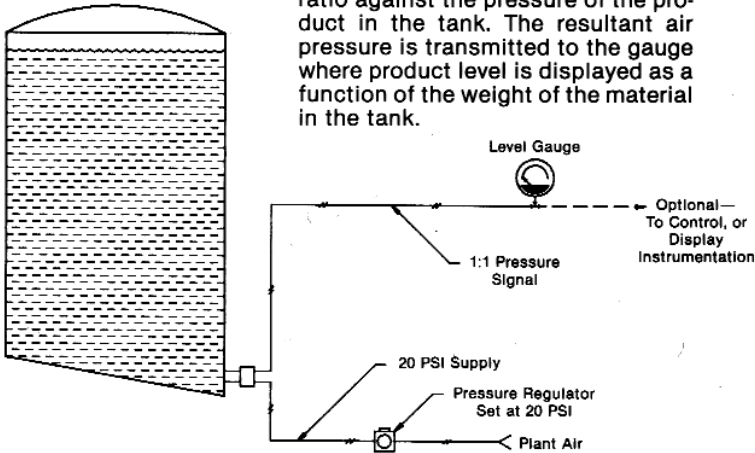

CHOICE OF SENSORS

Model 417 Level Sensor
1 1/2" NPT Mounting

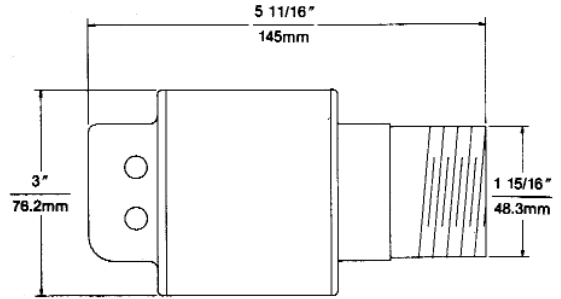

200 CFC-2" Level Sensor

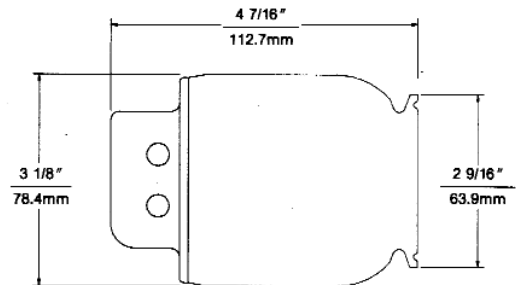

200 WFC Level Sensor

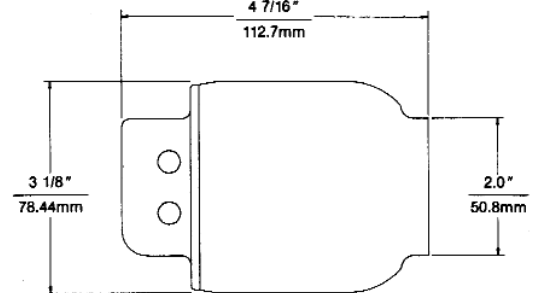

205 WFC Level Sensor for Insulated Tanks

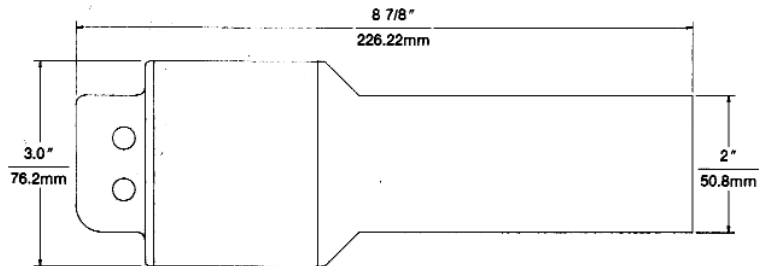

208 WFC Level Sensor for Inverted Tanks

