

Downpipe Level Sensor with 4" Dial Gauge & 5 Level Alarm

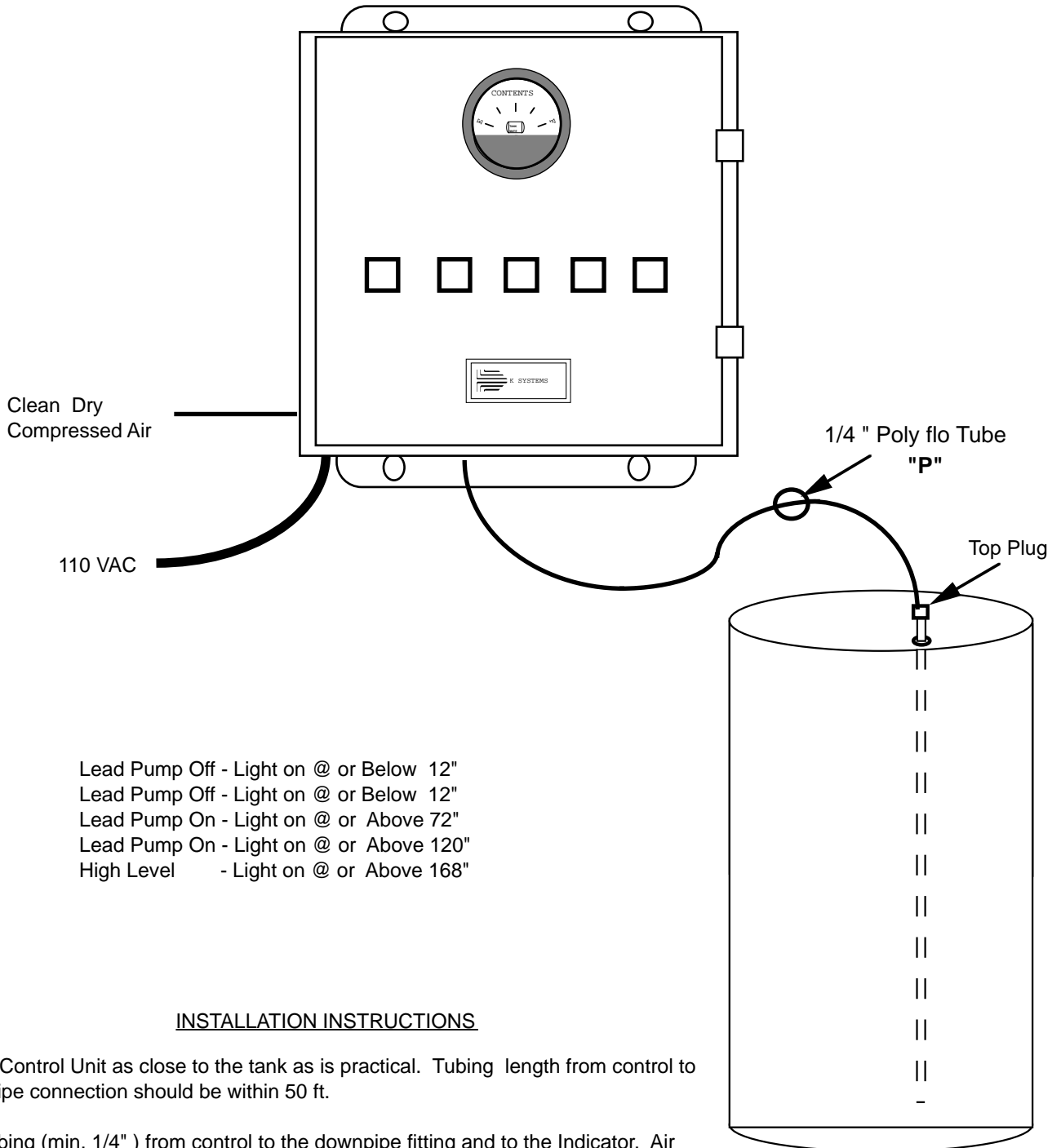

INSTALLATION INSTRUCTIONS

1. Mount Control Unit as close to the tank as is practical. Tubing length from control to downpipe connection should be within 50 ft.
2. Run tubing (min. 1/4") from control to the downpipe fitting and to the Indicator. Air leaks will produce erradict results in level readings.
3. Provide compressed air to the control and adjust the flow to 1 SCFH. Excessive flow or long tubing runs may produce an overpressure condition and result in high level readings. Lessening the flow should elevate this condition.

Supply Pressure: 100 PSIG maximum (minimum supply pressure is 5 PSI above the highest output pressure)

3 TANK HI-LO LEVEL ALARM SYSTEM

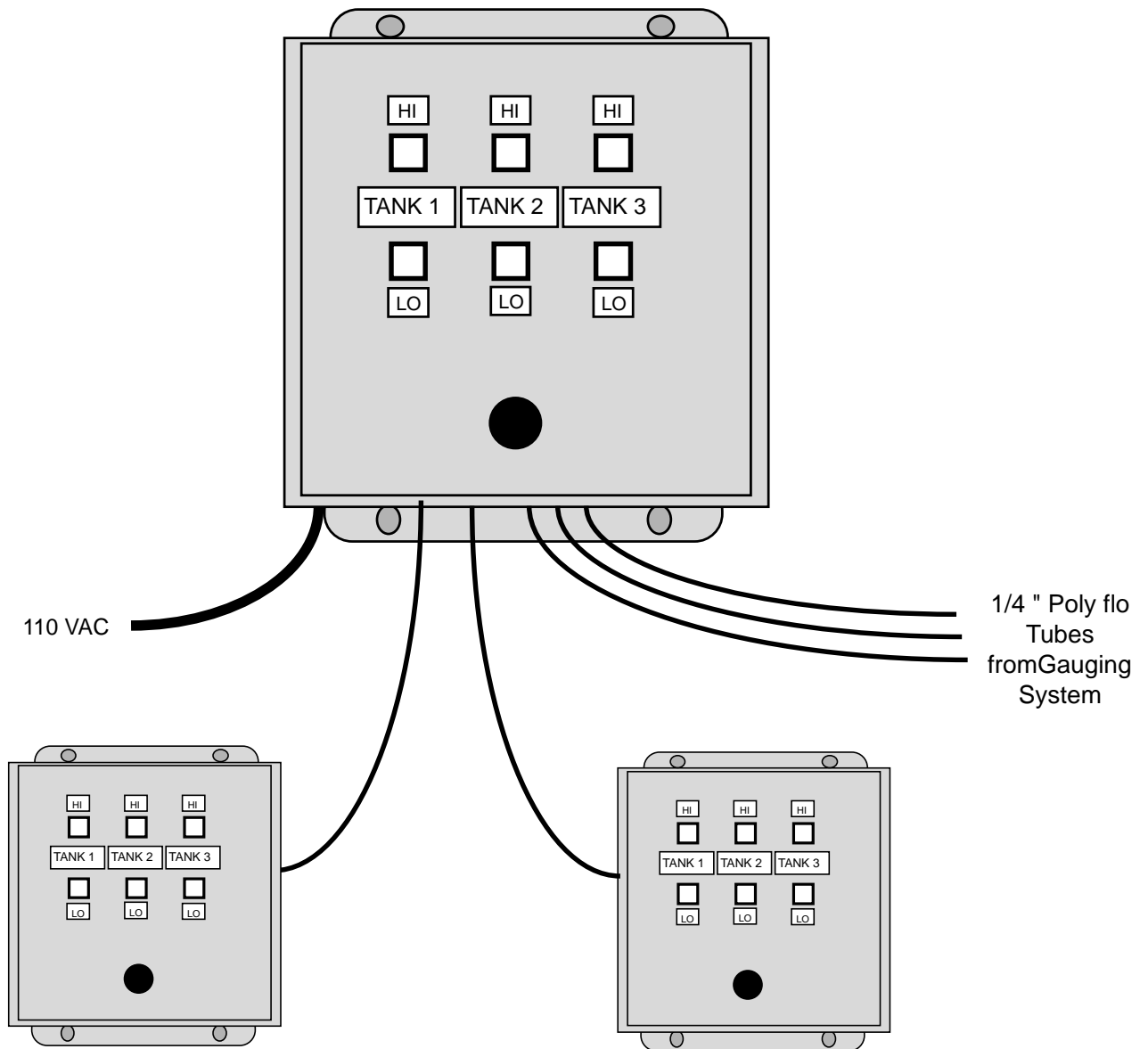

INSTALLATION INSTRUCTIONS

1. Mount system cabinets in desired location
2. Run tubing (min. 1/4") from Gauge line to the Main Alarm cabinet. Air leaks will produce erradict results .
3. Provide 115VAC to the alarm cabinet as indicated on the system prints
4. Run 8 wires to each remote cabinet from the main cabinet and connect to the terminals provided as marked.

Note: The remote cabinet lights and busser run on 115 VAC power from the main system cabinet